



Provis graphic
LIGHT UP YOUR BUSINESS

Catalog

illuminated signs

LICHTWERBUNG
KATALOG

2021

Creative Fabricated Solutions

KREATIVE LÖSUNGEN

We're inspired by your placemaking vision. For example, our specialty is producing custom, low - profile, trim - less fabricated illuminated graphics to stretch the possibilities of your design concept. Our letters can achieve 2mm letter stroke widths, and 1mm wide serifs without compromise in diffusion quality... and do all that in a low profile design (a little less than an inch deep)

WIR SIND VON IHRER VISION INSPIRIERT. UNSERE BESONDERHEIT IST ZUM BEISPIEL DIE HERSTELLUNG KUNDENSPEZIFISCHER, UNAUFFÄLLIGER, UMLEIMERLÖSER LEUCHTSCHILDER, UM DIE MÖGLICHKEITEN IHRES DESIGNKONZEPTS ZU ERWEITERN. UNSERE BUCHSTABEN KÖNNEN EINEN BUCHSTABENSTÄRKE VON 2 MM UND 1 MM SHERIF ERZIELEN, OHNE KOMPROMISSE BEI DER DIFFUSIONSQUALITÄT EINGEHEN ZU MÜSSEN... UND DAS ALLES IN EINEM FLACHEN DESIGN.



48h Quote Turnaround

48H ANGEBOTS-ABGABE

Submit your design, and we'll make sure you get a quote within 24 hours. Don't forget to submit your dimensional requirements, illumination specifications, and material preferences. For more complex projects, start a discussion with our engineering and design staff.

REICHEN SIE UNS IHR DESIGN EIN UND WIR SORGEN DAFÜR, DASS SIE EIN ANGEBOT INNERHALB VON 48 STUNDEN ERHALTEN. VERGESSEN SIE NICHT, IHRE MASSANFORDERUNGEN, BELEUCHTUNGSSPEZIFIKATIONEN UND MATERIALPRÄFERENZEN ANZUGEBEN. BEI KOMPLEXEREN PROJEKTEN SOLLTEN SIE EIN GESPRÄCH MIT UNSEREN INGENIEUREN UND KONSTRUKTEUREN VEREINBAREN..



20 Day Delivery

20 TAGE LIEFERUNG

In most cases once you submit your vector artwork, we can manufacture your custom letter forms and deliver to your door within 20 days from art approval.

IN DEN MEISTEN FÄLLEN KÖNNEN WIR, SOBALD SIE IHRE VEKTORGRAFIKEN EINGEREICHT HABEN, IHRE BENUTZERDEFINIERTEN BUCHSTABEN ODER ZEICHEN HERSTELLEN UND DIESE INNERHALB VON 20 TAGEN NACH IHRER BESTÄTIGUNG AN IHRE HAUSTÜR LIEFERN.



3 Year Warranty

3 JAHRE GARANTIE

We provide a 3-year guarantee for our products against manufacturing defects from the date of shipment. All of our products are packaged with a foam-in-place polyurethane packaging to conform to the shape of the letters to prevent damage caused by shipping & handling.

WIR GEWÄHREN AUF UNSERE PRODUKTE EINE GARANTIE VON 3 JAHREN AB VERSANDDATUM. ALLE UNSERE PRODUKTE SIND IN AUFGESCHÄUMTEN POLYURETHANVERPACKUNG VERPACKT, DIE SICH AN DIE FORM DER BUCHSTABEN ANPASST, UM SCHÄDEN DURCH VERSAND UND HANDHABUNG ZU VERMEIDEN.

Contents

INHALT

Profile / Profil 1	2
Profile / Profil 3 / 3S	4
Profile / Profil 4	6
Profile / Profil 4XL	8
Profile / Profil 5	10
Profile / Profil 5S	12
Profile / Profil R	14
Profile / Profil 8	16
Profile / Profil 11f	18
Profile / Profil 11FS	20
Profile / Profil 11fb	22
Profile / Profil 11s	24
Profile / Profil 11bS	26
Profile / Profil 11b	28
Profile / Profil 11n	30
Profile / Profil 11c	32
Profile / Profile Xf	34
Profile / Profile Xb	36
Light box / Leuchtkasten	38
PVC Textile box / PVC Textile box	40
Our History	42
Powder Coatings '21	

OPCIJE MONTAZE PROFILA
OZNACENE SU IKONICAMA?

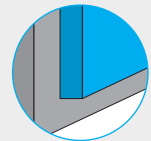

Direct on surface
Wandmontage

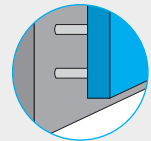

Direct on surface
with spacers
mit Abstandhaltern

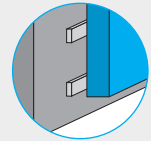

Mounting rails
Underconstruction /
Unterkonstruktion

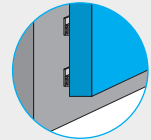

Mounting rails
/ Aluminum
EASY™ Profiles

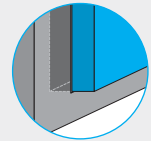

Concealed
construction
Unterputzschiene

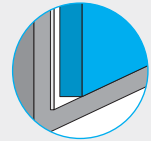

With back panel
Grundplatte

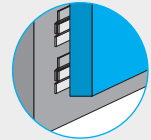

With Z-Profile
mit Z-Winkel

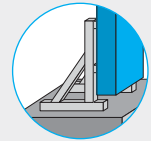

Roof construction
Dachkonstruktion

Direct on surface
WANDMONTAGE

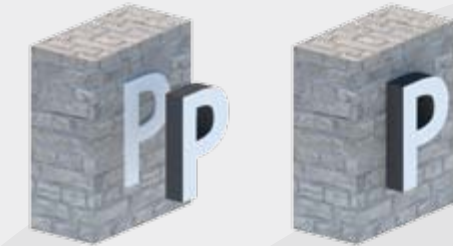
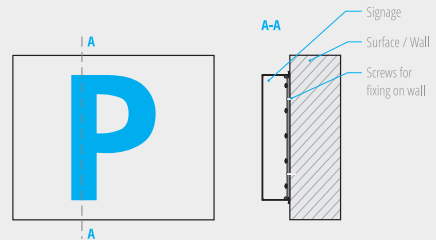

Direct on surface with spacers
MIT ABSTANDHALTERN

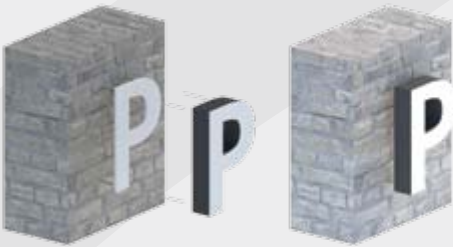
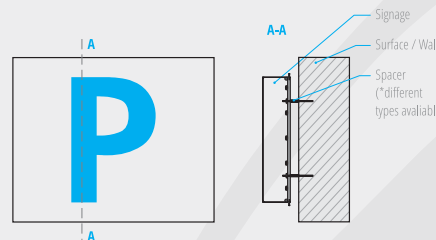

Mounting rails
UNDERCONSTRUCTION / UNTERKONSTRUKTION

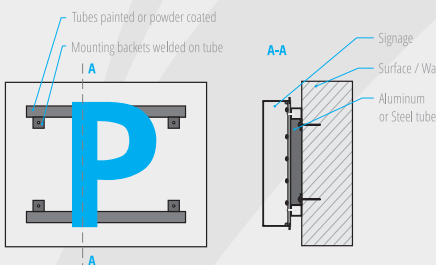

Mounting rails / Aluminum EASY™ Profiles

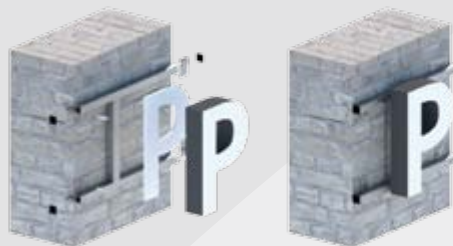
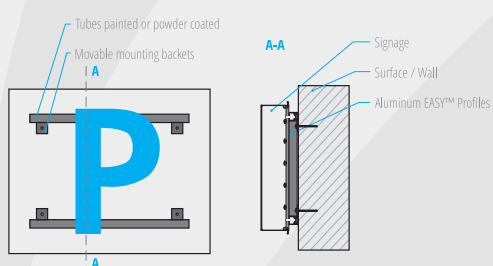

Concealed construction
UNTERPUTZSCHIENE

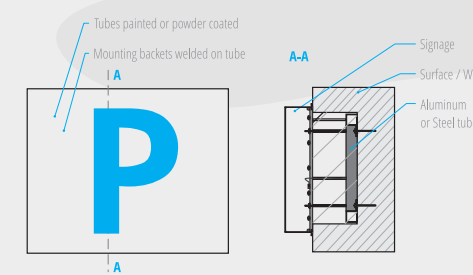

With back panel
GRUNDPLATTE

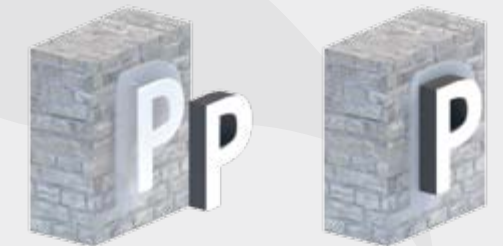
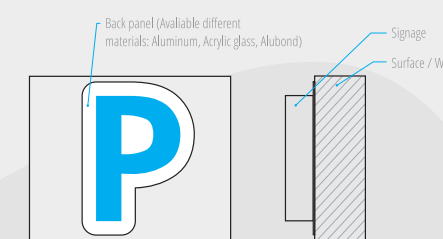

With Z-Profile
MIT Z-WINKEL

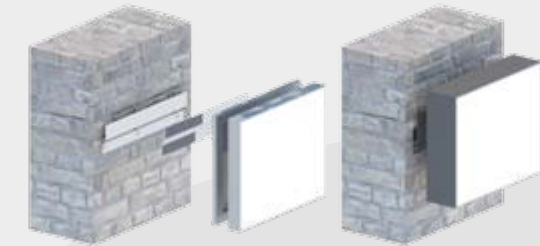
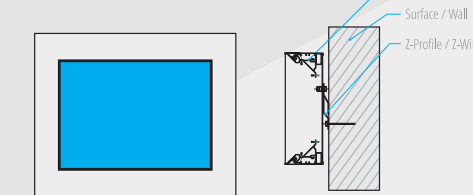

Roof construction
DACHKONSTRUKTION

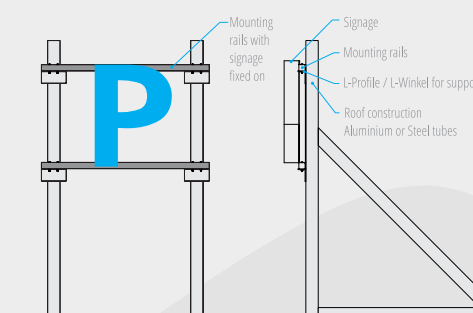

- non-illuminated
UNBELEUCHTET
- aluminum front and sides
(Profile 1v1)
FRONT UND SEITENTEILE
AUS ALUMINIUM

- PVC hard foam back
(Profile 1v1)
RÜCKWAND AUS PVC HARTSCHAUM
- made of acrylic block
(Profile 1v2)
HERGESTELLT AUS ACRYLBLOCK

- RAL paint color matching
available
RAL FARBABSTIMMUNG
VERFÜGBAR

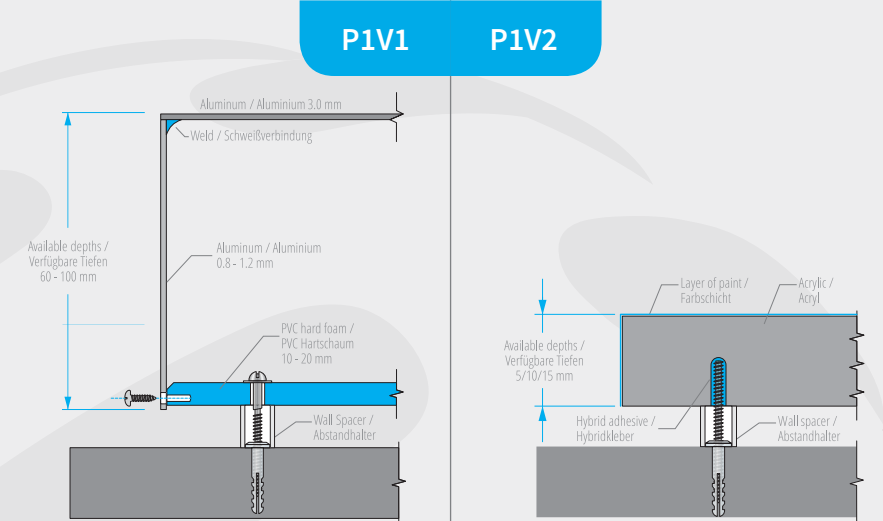
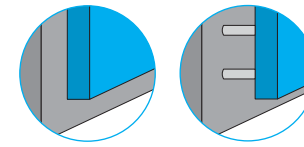

	v1	v2
letter height / Buchstabenhöhe	50 - 1500 mm	350 - 2000 mm
minimum stroke / Buchstabenstärke min.	10 mm	30 mm
letter depth / Buchstabentiefe	5 - 30 mm	30 - 120 mm

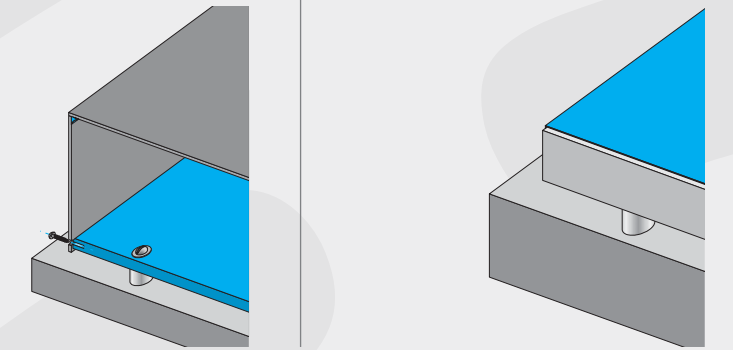

halo-lit (P3) / halo-lit - partially side-lit (P3S)
RÜCKLEUCHTER / RÜCK-UND TEILWEISE SEITENLEUCHTER

front and sides made of aluminum, back made of translucent acrylic (P3)
FRONT UND SEITENTEILE AUS ALUMINIUM, RÜCKWAND AUS LICHRDURCHLÄSSIGEM ACRYLGLAS (P3)

front and part of the sides made of aluminum, back and part of the sides made of acrylic block (P3S)
FRONT UND TEIL DER SEITEN AUS ALUMINIUM, RÜCKWAND UND TEILWEISE SEITEN AUS ACRYLBLOCK (P3S)

front and partially sides painted-powder coated
FRONT UND TEILWEISE SEITEN LACKIERT-PULVERBESCHICHTET

backlit/halo with LED modules
RÜCKLEUCHTER MIT LED MODULEN

front and sides painted-powder coated
FRONT UND SEITENTEILE LACKIERT-PULVERBESCHICHTET

RAL paint color matching available
RAL FARBABSTIMMUNG VERFÜGBAR

interior painted in reflective white
VON INNEN MIT REFLEKTIERENDEM WEIß LACKIERT

P3	P3S
letter height / Buchstabenhöhe 350 - 2000 mm	350 - 1200 mm
minimum stroke / Buchstabenstärke min. 30 mm	30 mm
letter depth / Buchstabentiefe 50 - 120 mm	50 - 110 mm



P3

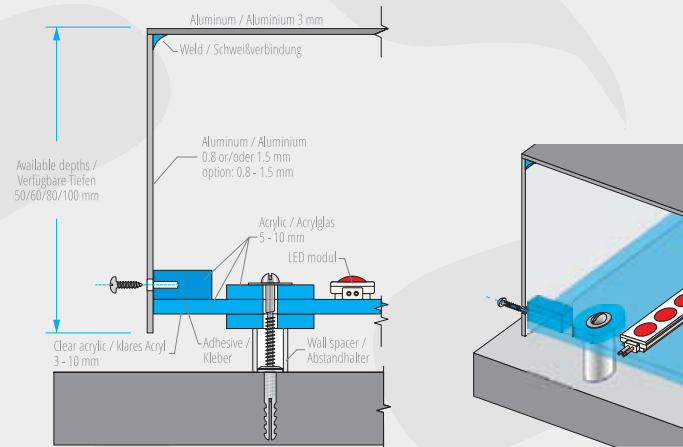

P3S

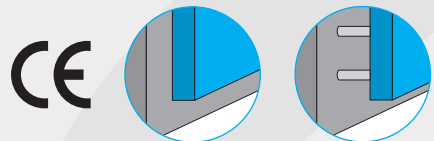
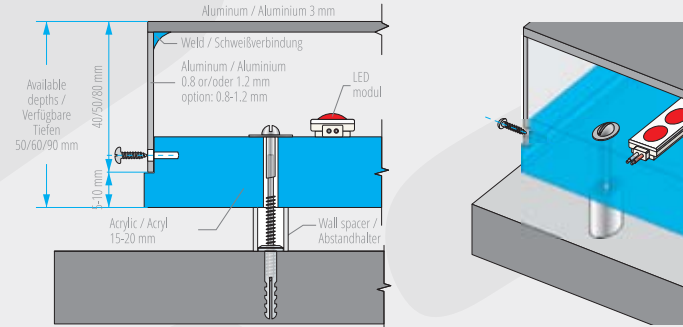

- front-lit
FRONTLEUCHTER
- front made of translucent acrylic
FRONT AUS LICHTDURCHLÄSSIGEM ACRYLGLAS
- sides and back made of aluminum
SEITENTEILE UND RÜCKWAND AUS ALUMINIUM
- front secured with aluminum L-profile
FRONT BEFESTIGT MIT ALUMINIUM L-PROFIL
- sides and back painted-powder coated
SEITENTEILE UND RÜCKWAND LACKIERT-
PULVERBESCHICHTET

- RAL paint color matching available
RAL FARBABSTIMMUNG VERFÜGBAR
- interior painted in reflective white
VON INNEN MIT REFLEKTIERENDEM WEIß LACKIERT

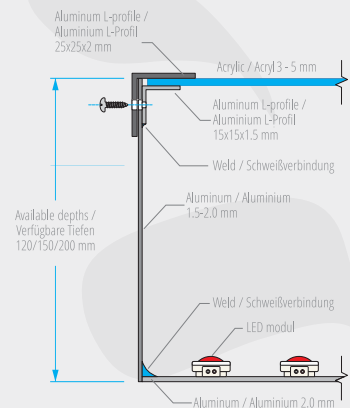
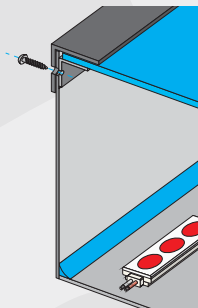
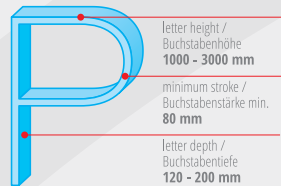
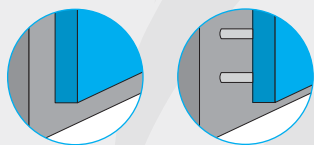



- ☛ front-lit
FRONTLEUCHTER
- ☛ front made of translucent PVC fabric
FRONT AUS LICHTDURCHLÄSSIGEM SPANN-TUCHGEWEBE
- ☛ sides and back made of aluminum
SEITENTEILE UND RÜCKWAND AUS ALUMINIUM
- ☛ sides and back painted-powder coated
SEITENTEILE UND RÜCKWAND LACKIERT- PULVERBESCHICHTET
- ☛ RAL paint color matching available
RAL FARBABSTIMMUNG VERFÜGBAR
- ☛ interior painted in reflective white
VON INNEN MIT REFLEKTIERENDEM WEIß LACKIERT

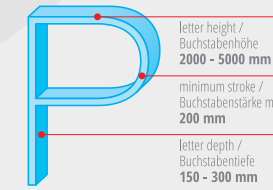
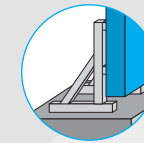
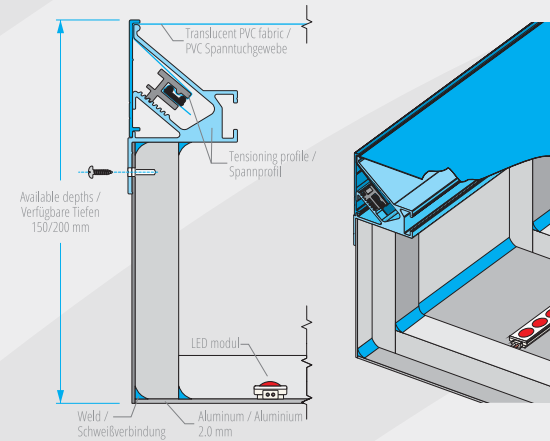



- front-lit
FRONTLEUCHTER
- PVC trim cap
PVC UMLEIMER
- front made of translucent acrylic
FRONT AUS LICHTDURCHLÄSSIGEM ACRYL
- sides and back made of aluminum
SEITENTEILE UND RÜCKWAND AUS ALUMINIUM

- sides and back painted-powder coated
SEITENTEILE UND RÜCKWAND
LACKIERT-PULVERBESCHICHTET
- RAL paint color matching available
RAL FARBABSTIMMUNG VERFÜGBAR
- interior painted in reflective white
VON INNEN MIT REFLEKTIERENDEM
WEIß LACKIERT

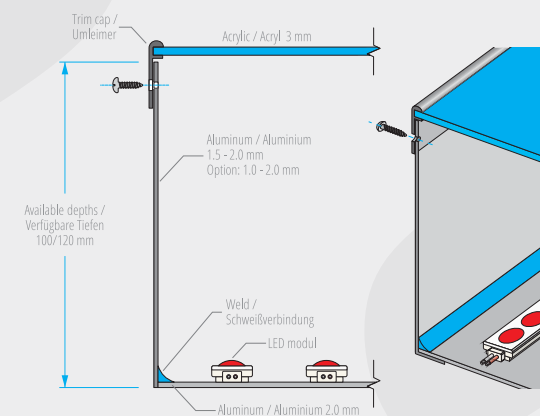
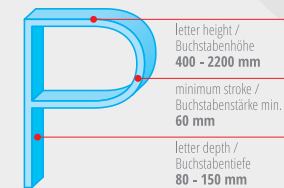
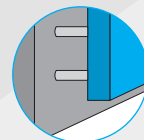
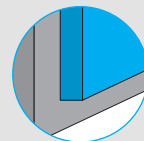

- front-lit
FRONTLEUCHTER
- front mounted without trim-cap
ACRYL BEFESTIGT OHNE UMLEIMER
- front made of translucent acrylic
FRONT AUS LICHTDURCHLÄSSIGEM ACRYL
- sides made of aluminum
SEITENTEILE AUS ALUMINIUM
- PVC hard foam back
RÜCKWAND AUS PVC HARTSCHAUM
- RAL paint color matching available
RAL FARBABSTIMMUNG VERFÜGBAR
- interior painted in reflective white
VON INNEN MIT REFLEKTIERNDEM WEIß LACKIERT

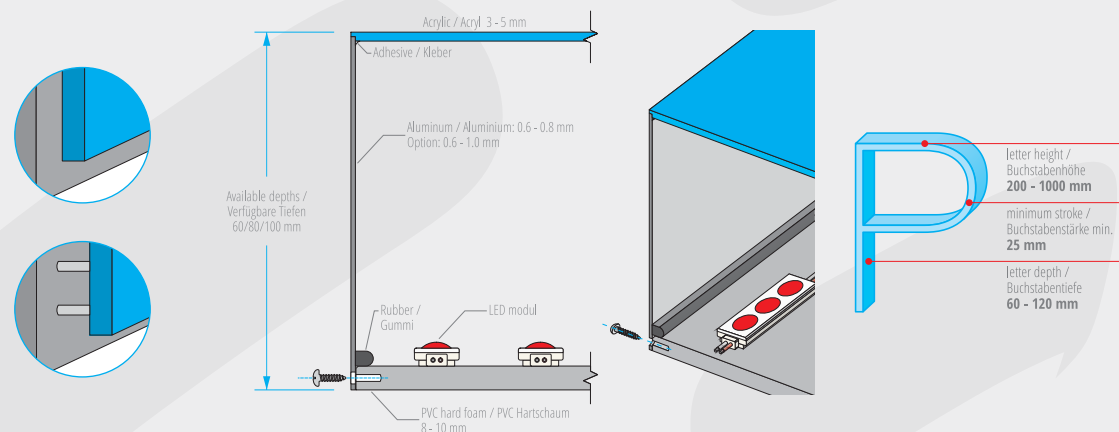

- ⊗ front-lit
FRONTLEUCHTER
- ⊗ front mounted without trim-cap
ACRYL BEFESTIGT OHNE UMLEIMER
- ⊗ front made of translucent acrylic
FRONT AUS LICHTDURCHLÄSSIGEM ACRYL
- ⊗ sides made of aluminum
SEITENTEILE AUS ALUMINIUM
- ⊗ PVC hard foam back
RÜCKWAND AUS PVC HARTSCHAUM
- ⊗ RAL paint color matching available
RAL FARBABSTIMMUNG VERFÜGBAR
- ⊗ interior painted in reflective white
VON INNEN MIT REFLEKTIERNDEM WEIß LACKIERT

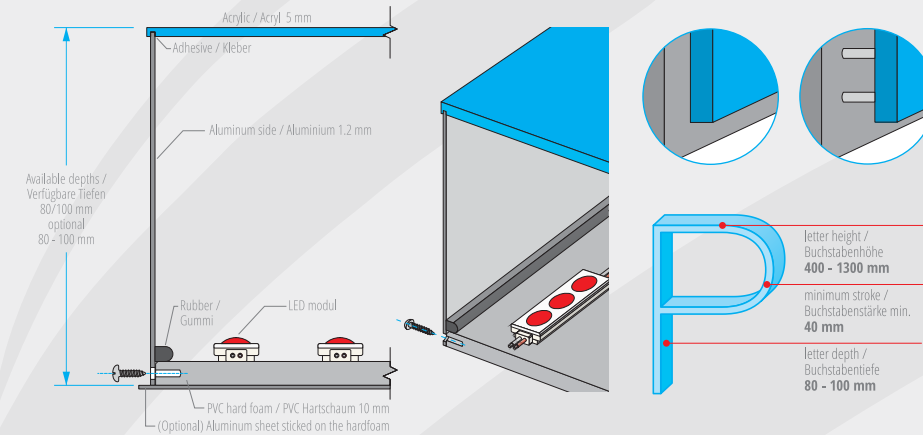



- front and side-lit
FRONT-UND SEITENLEUCHTER
- front and sides made of translucent acrylic
FRONT AUS LICHTDURCHLÄSSIGEM ACRYL

- PVC hard foam back
RÜCKWAND AUS PVC HARTSCHAUM
- RAL paint color matching available
RAL FARBABSTIMMUNG VERFÜGBAR

- interior painted in reflective white
VON INNEN MIT MIT REFLEKTIERNDEM WEIß LACKIERT

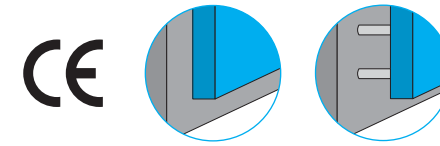

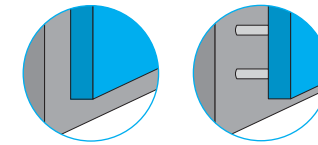

- fine-stroked front-lit letter
FEIN GESTRICHENE FRONTLEUCHTER
- made of full acrylic block
HERGESTELLT AUS VOLLACRYLBLOCK
- single embedded and sealed Nichia LEDs
EINZELNE INTEGRIERTE UND VERSIEGELTE NICHIA LEDs
- sides and back painted
SEITENTEILE UND RÜCKWAND LACKIERT

- RAL paint color matching available
RAL FARBABSTIMMUNG VERFÜGBAR

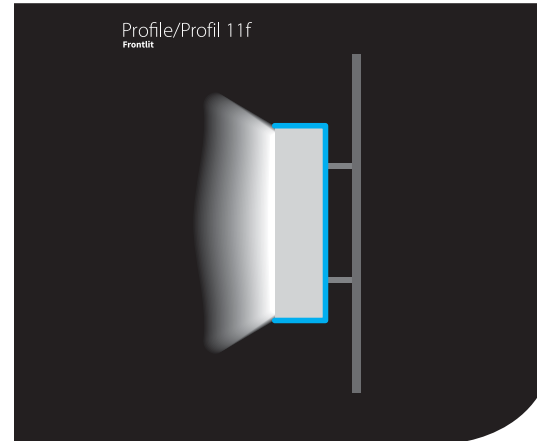
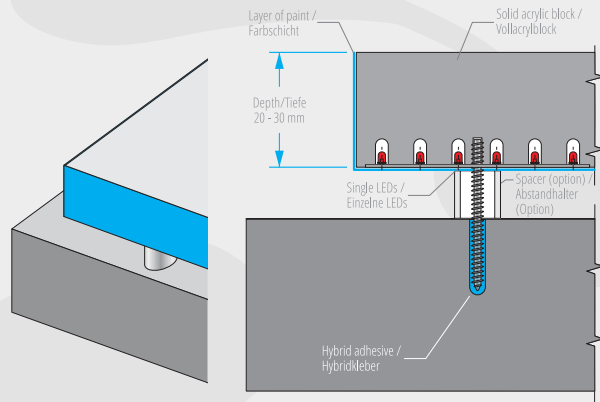
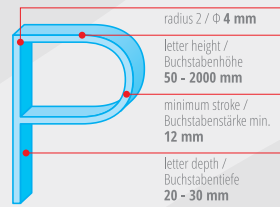

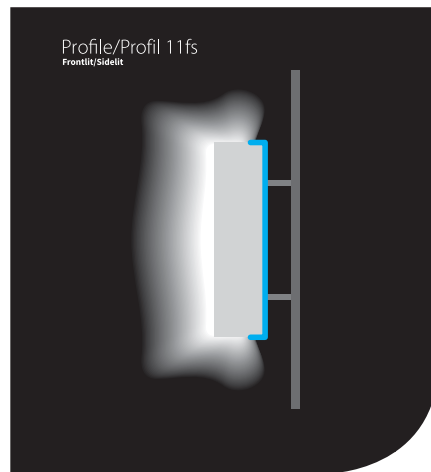

fine-stroked front and side-lit letter
FEIN GESTRICHENE FRONT- UND SEITENLEUCHTER

made of full acrylic block
HERGESTELLT AUS VOLLACRYLBLOCK

single embedded and sealed Nichia LEDs
EINZELNE INTEGRIERTE UND VERSIEGELTE NICHIA LEDS

sides partially and back painted
SEITENTEILE TEILWEISE UND RÜCKWAND LACKIERT

RAL paint color matching available
RAL FARBABSTIMMUNG VERFÜGBAR

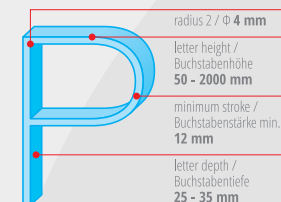
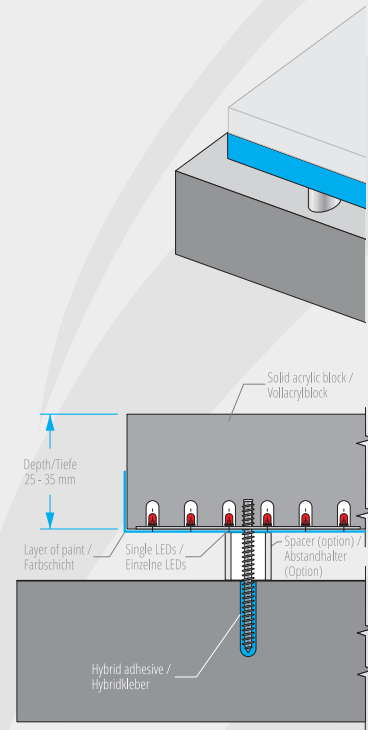
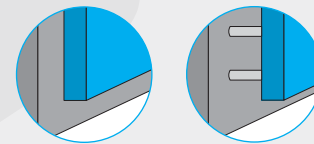

- ⚙️ fine-stroked front and backlit letter
FEIN GESTRICHENE FRONT- UND RÜCKLEUCHTER
- ⚙️ single embedded and sealed Nichia LEDs
EINZELNE INTEGRIERTE UND VERSIEGELTE NICHIA LEDS
- ⚙️ RAL paint color matching available
RAL FARBABSTIMMUNG VERFÜGBAR
- ⚙️ made of full acrylic block
HERGESTELLT AUS VOLLACRYLBLOCK
- ⚙️ sides painted
SEITENTEILE LACKIERT

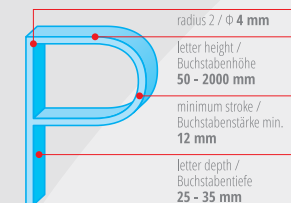
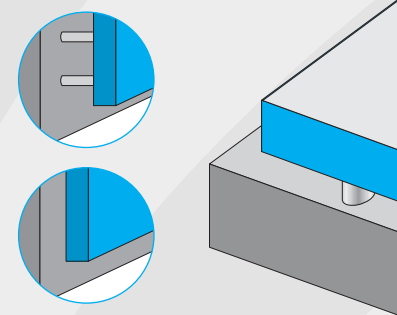
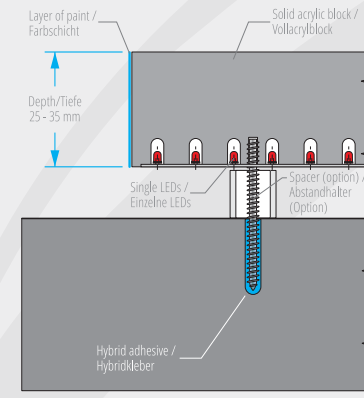
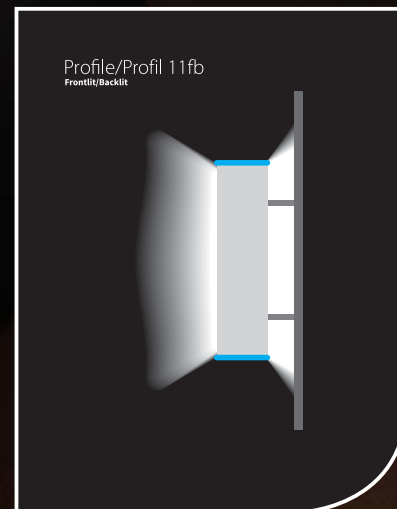

- fine-stroked side-lit letter
FEIN GESTRICHENE SEITENLEUCHTER
- made of full acrylic block
HERGESTELLT AUS VOLLACRYLBLOCK
- single embedded and sealed Nichia LEDs
EINZELNE INTEGRIERTE UND VERSIEGELTE NICHIA LEDs
- front and back painted
FRONT UND RÜCKWAND LACKIERT
- RAL paint color matching available
RAL FARBABSTIMMUNG VERFÜGBAR

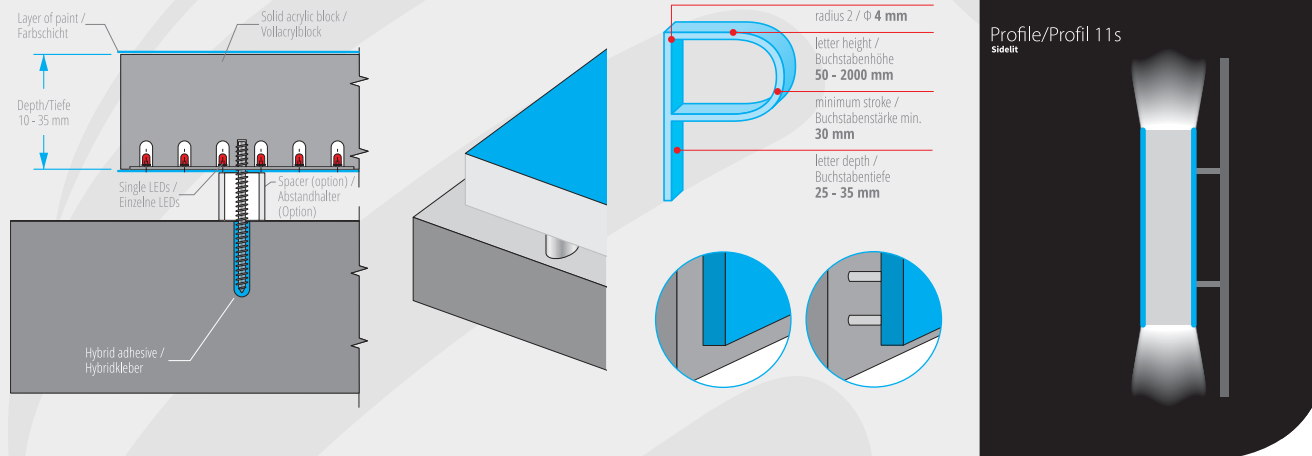

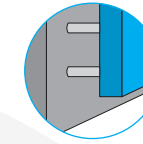
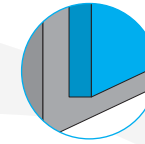

- fine-stroked back and side-lit letter
FEIN GESTRICHENE RÜCK-UND SEITENLEUCHTER
- made of full acrylic block
HERGESTELLT AUS VOLLACRYLBLOCK
- single embedded and sealed Nichia LEDs
EINZELNE INTEGRIERTE UND VERSIEGELTE NICHIA LEDs
- front and sides partially painted
FRONT UND TEILWEISE SEITENTEILE LACKIERT
- RAL paint color matching available
RAL FARBABSTIMMUNG VERFÜGBAR

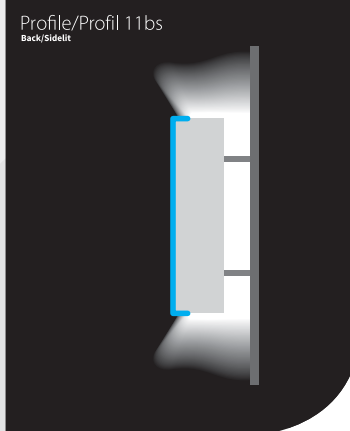
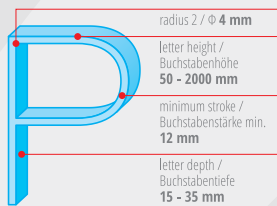
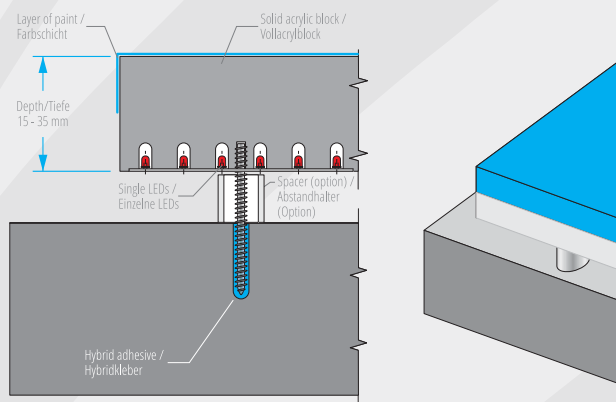

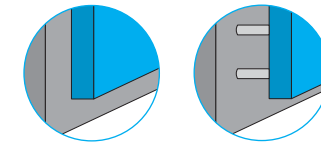

- fine-stroked back-lit letter
FEIN GESTRICHENE RÜCKLEUCHTER
- made of full acrylic block
HERGESTELLT AUS VOLLACRYLBLOCK
- single embedded and sealed Nichia LEDs
EINZELNE INTEGRIERTE UND VERSIEGELTE NICHIA LEDs
- front and sides painted
FRONT UND SEITENTEILE LACKIERT
- RAL paint color matching available
RAL FARBABSTIMMUNG VERFÜGBAR

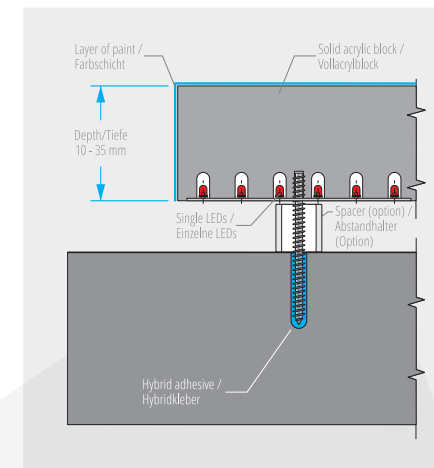
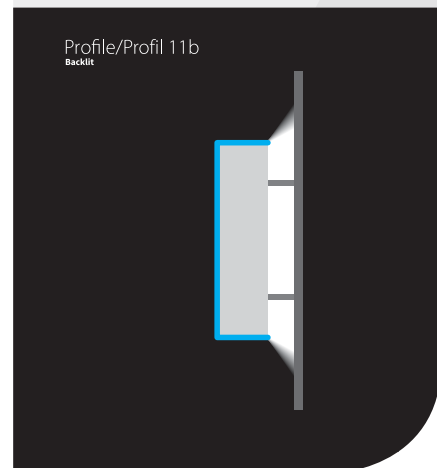
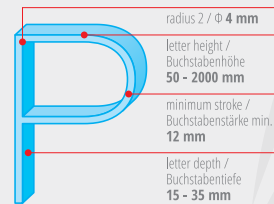

NEW
Profile

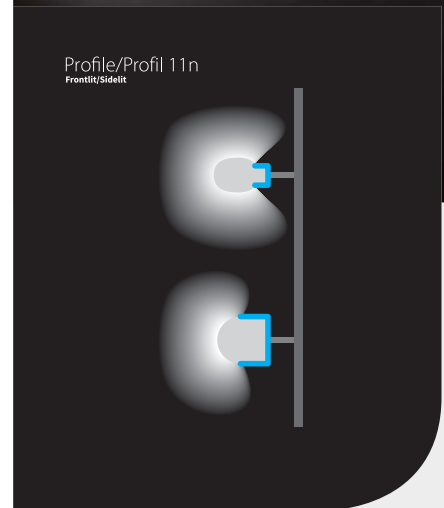

☞ fine-stroked neon imitation
letter
FEIN GESTRICHENE NEON-IMITATION

☞ made of full acrylic block
HERGESTELLT AUS
VOLLACRYLBLOCK

☞ front and back painted
FRONT UND RÜCKWAND
LACKIERT

☞ single embedded and sealed
Nichia LEDs
EINZELNE INTEGRIERTE UND
VERSIEGELTE NICHIA LEDs

☞ RAL paint color matching
available
RAL FARBABSTIMMUNG
VERFÜGBAR

radius 2 / \varnothing 4 mm
letter height /
Buchstabenhöhe
50 - 2000 mm
minimum stroke /
Buchstabenstärke min.
10 mm
letter depth /
Buchstabentiefe
25 - 35 mm

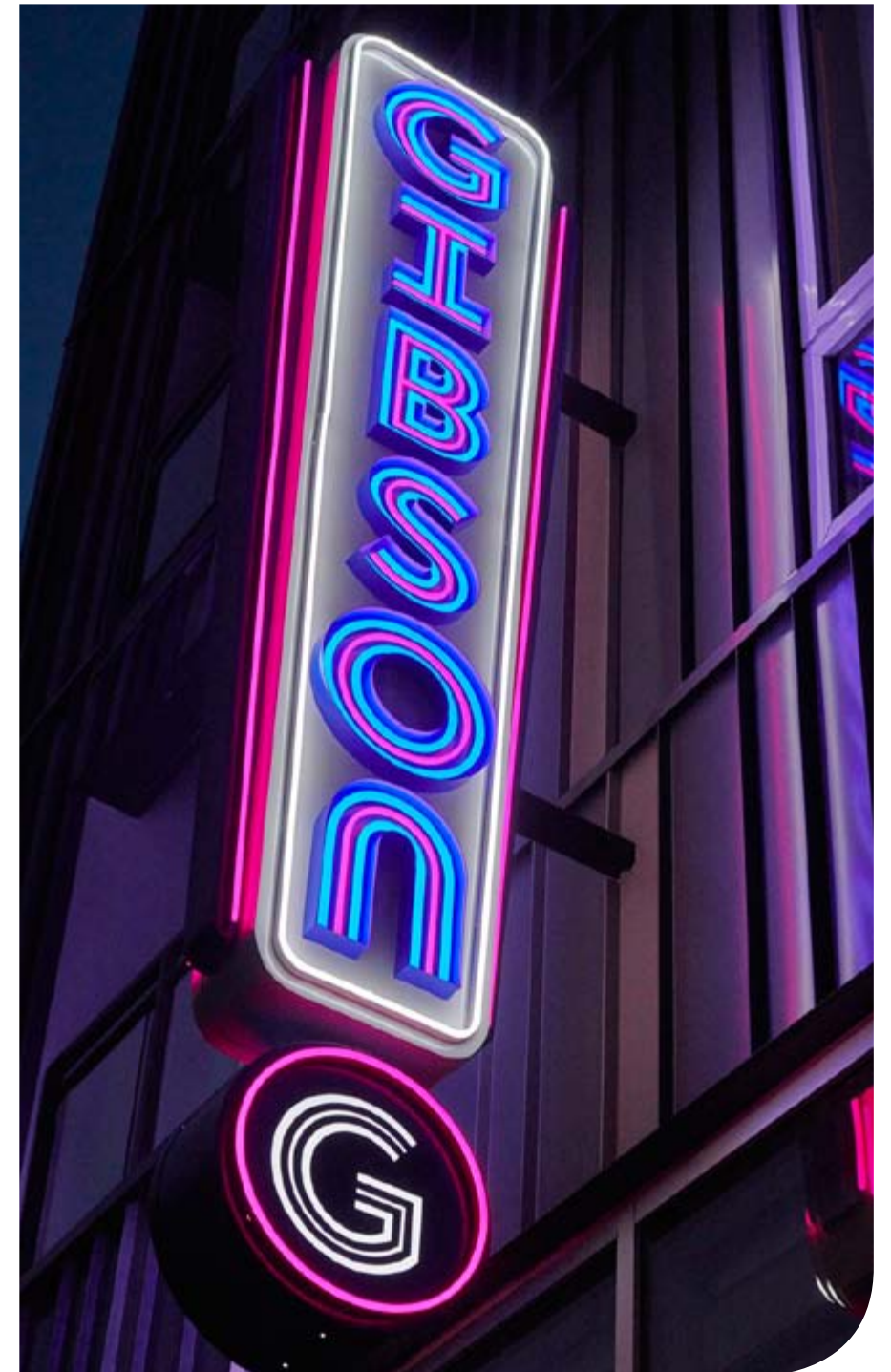
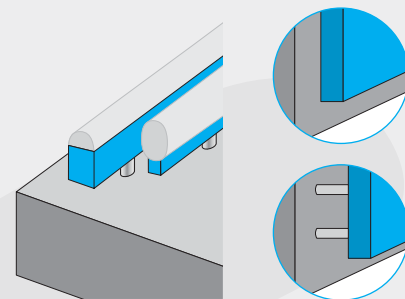
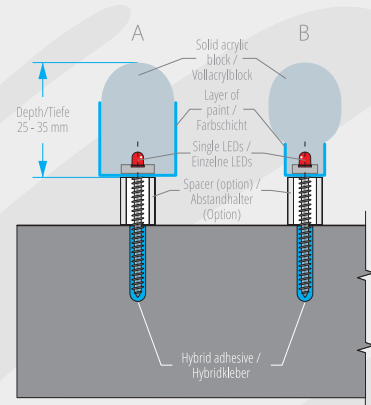

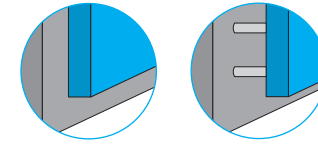

NEW
Profile

- super fine-stroked letter
SUPERFEIN GESTRICHENE FRONTLEUCHTER
- made of full acrylic block
HERGESTELLT AUS VOLLACRYLBLOCK
- single embedded and sealed Nichia LEDs
EINZELNE INTEGRIERTE UND VERSIEGELTE NICHIA LEDS
- sides and back painted
SEITEN UND RÜCKWAND LACKIERT
- RAL paint color matching available
RAL FARBABSTIMMUNG VERFÜGBAR

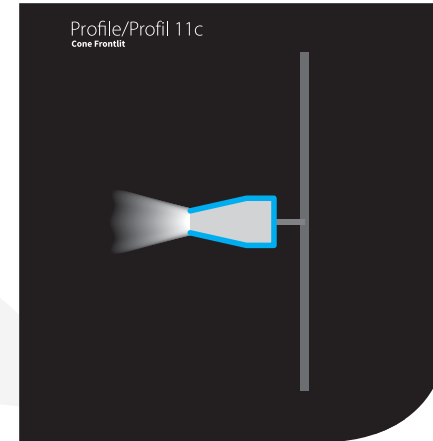
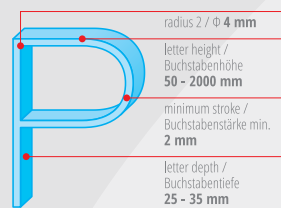
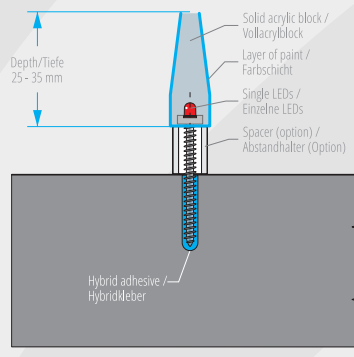

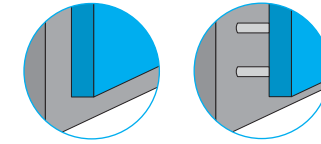

- options
OPTIONEN
- Inset acrylic
EINGESETZER ACRYL
- leveled acrylic
NIVELIERTES ACRYL
- push-through acrylic
DURCHGESTECKTES ACRYL
- light box made of Aluminum
or ACP
LEUCHTKASTEN AUS
ALUMINIUM ODER ACP
- Letter front made of acrylic
BUCHSTABENFRONT AUS ACRYL

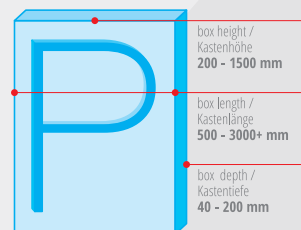
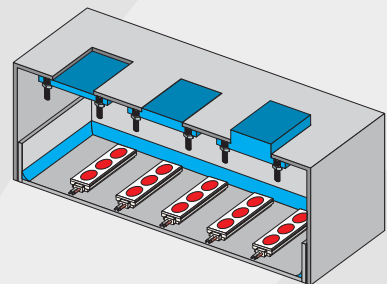
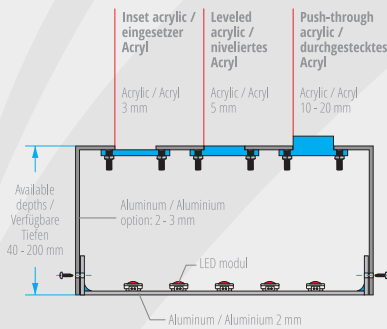

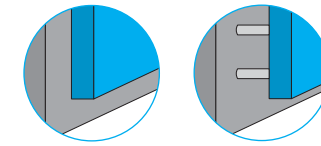

DOPPELSEITIG LED-SCHILD



☞ Low profile depth from 20 mm to 30 mm
ACRYLGLAS TIEFE VON 20MM BIS 30MM

☞ Height from 300mm up to 800mm
HÖHE VON 300MM BIS 800MM

☞ Width from 300mm up to 800mm
BREITE VON 300MM BIS 800MM

☞ Letterforms can be pushed through up to 5mm
LOGOS/TEXT DURCHGESTECKT BIS 5MM

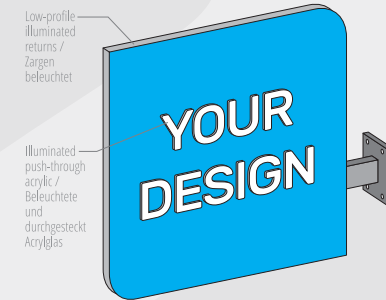
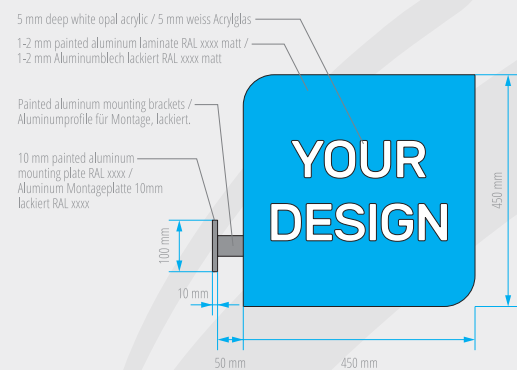

Options
OPTIONEN

Inset Acrylic
ACRYLGLAS HINTERLEGT

Flush acrylic
FLACHBUNDIG ACRYLGLAS

Push-through acrylic
DURCHGESTECKT ACRYLGLAS

Totem/Pylon made of Aluminum or Stainless steel
PYLON AUS ALUMINUM, STAHL ODER ALUDIBOND

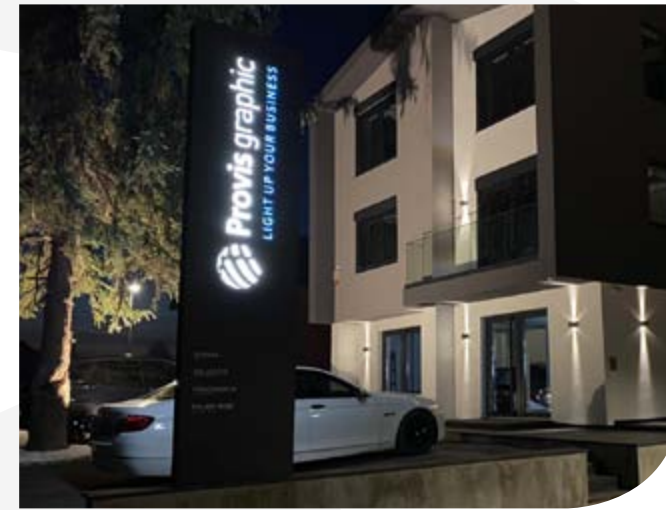
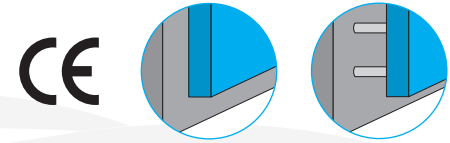
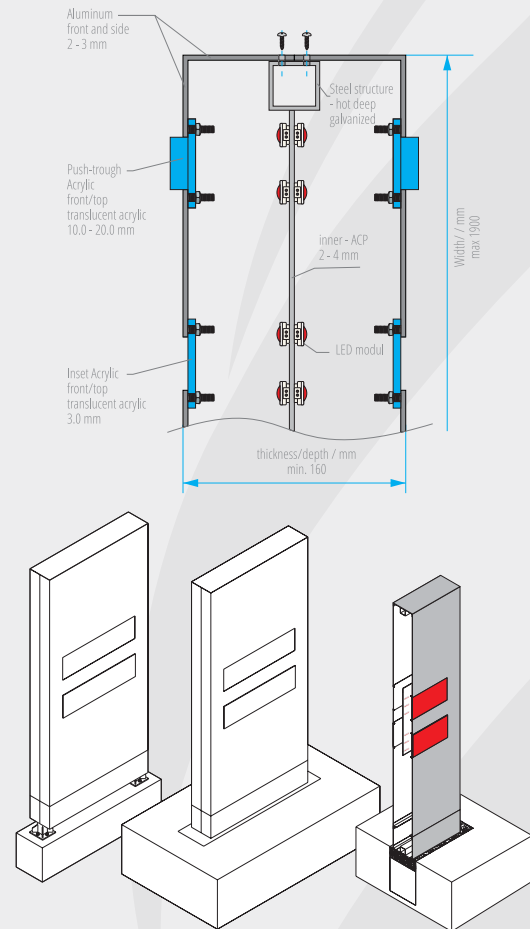

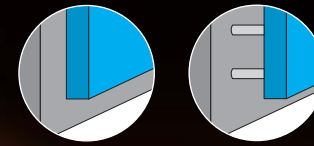

- front made of PVC fabric
FRONT AUS PVC SPANNTUCHGEWEBE
- aluminum or ACP back
RÜCKWAND AUS ALUMINIUM ODER ACP
- front-lit with LED modules
FRONTLEUCHTER MIT LED MODULE
- sides and back painted-powder coated
SEITENTEILE UND RÜCKWAND
LACKIERT-PULVERBESCHICHTET

- RAL paint color matching available
RAL FARBABSTIMMUNG VERFÜGBAR
- interior painted in reflective white
VON INNEN MIT REFLEKTIERENDEM WEIß LACKIERT

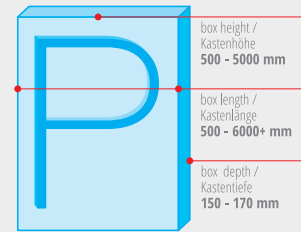

TBox V1

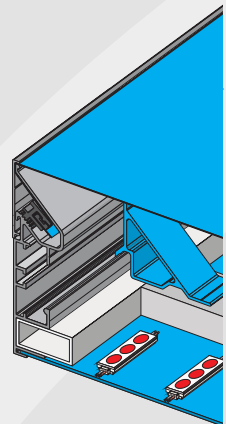
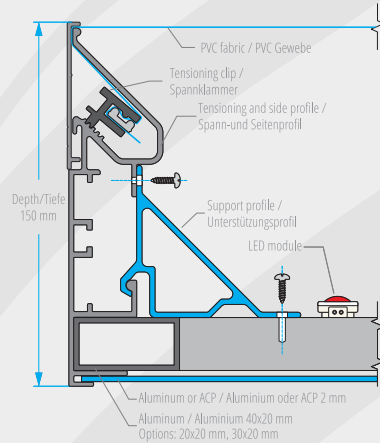

TBox V2

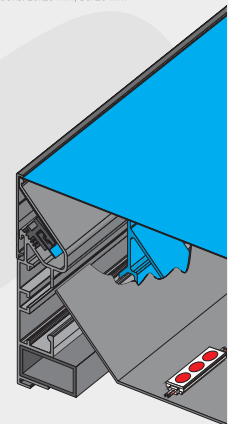
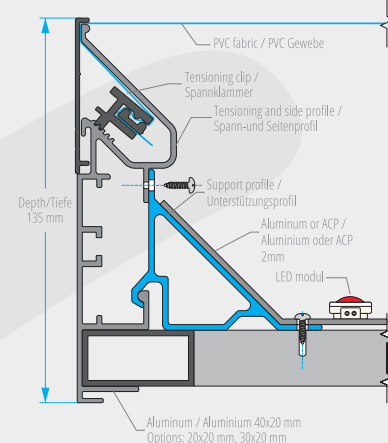

TBox V3

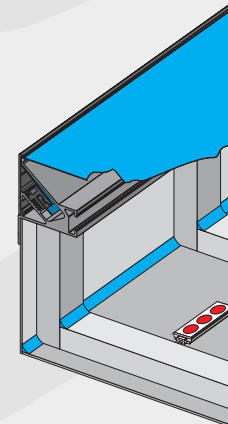
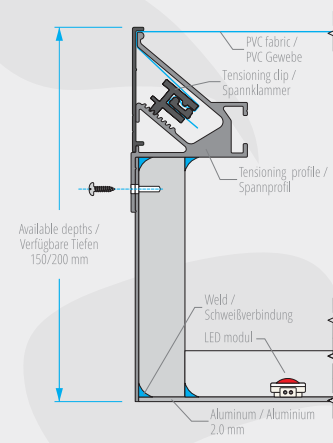

- ☞ An ideal and easy way to install. The main advantage is the movable bar.

PREVOD PREVOD PREVOD
PREVOD PREVOD PREVOD
PREVOD PREVOD PREVOD
PREVOD PREVOD PREVOD
PREVOD PREVOD

- ☞ The possibility of painting and powder coating in color according to customer request.

PREVOD PREVOD PREVOD
PREVOD PREVOD PREVOD
PREVOD PREVOD PREVOD
PREVOD PREVOD PREVOD
PREVOD PREVOD

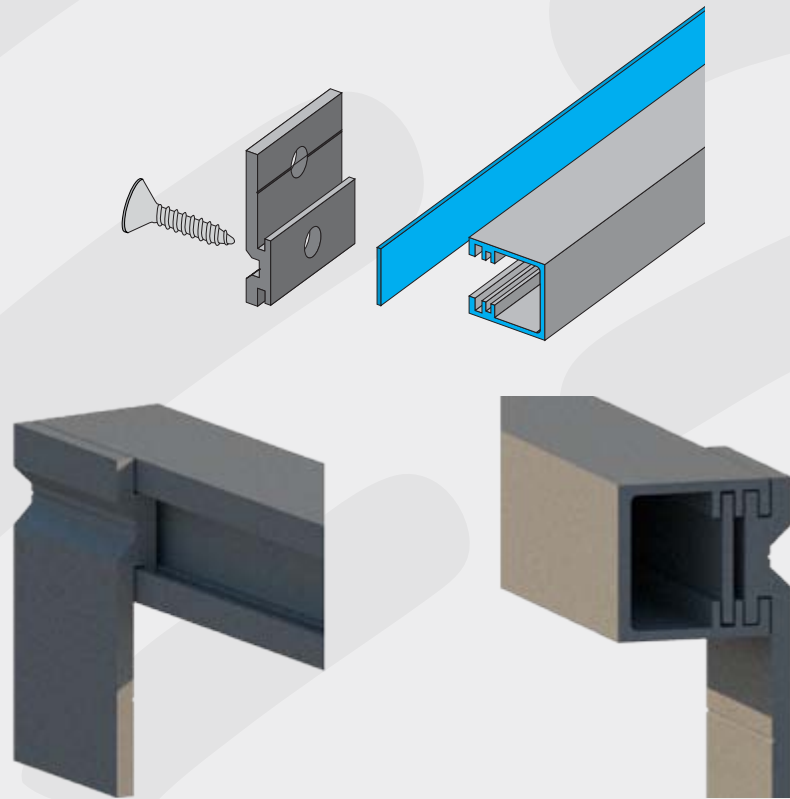
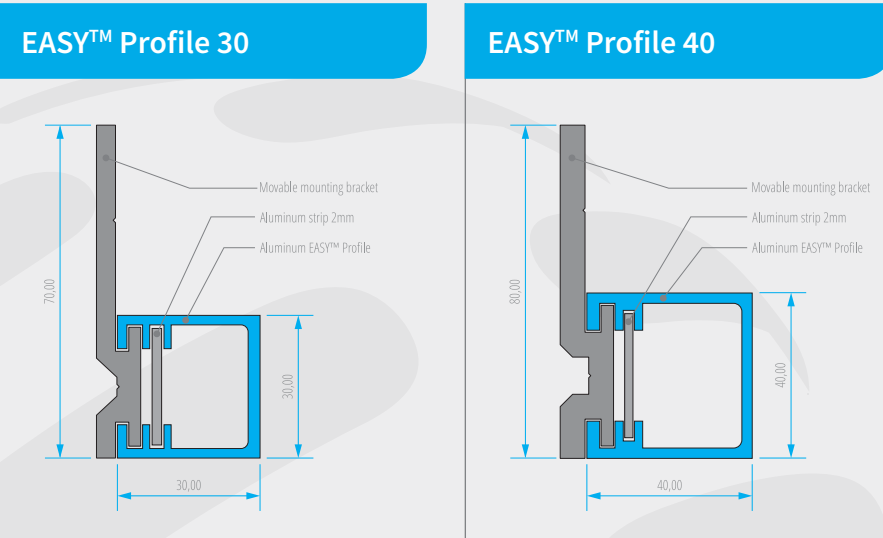

Our History

1997 Provis Foundation | PROVIS GRÜNDUNG

Following the Balkan Wars, Provis was founded as a father and son team with a production area of less than 40 sqm and three employees. They focused on building credibility, respect, and trust among their suppliers and customers through ensuring the highest quality of products and customer service. They understood that if they treated their partners right, chances are, they'd be successful too.

First Investment - looking back on it, was insignificant. But for a company starting from the ashes of war, it was a big milestone to add new 60 sqm to our office and future headquarters.

NACH DEN BALKANKRIEGEN WURDE PROVIS ALS VATER-SOHN-TEAM MIT EINER PRODUKTIONSFLÄCHE VON WENIGER ALS 40 QUADRATMETER UND DREI MITARBEITERN GEGRÜNDET. SIE KONZENTRIERTEN SICH DARAUFGLAUBWÜRDIGKEIT, RESPEKT UND VERTRAUEN BEI IHREN LIEFERANTEN UND KUNDEN AUFZUBAUEN, INDEM SIE HÖCHSTE QUALITÄT UND KUNDENSERVICE SICHERSTELTEN. SIE HABEN VERSTANDEN, DASS SIE AUCH ERFOLGREICH SEIN WERDEN, WENN SIE IHRE PARTNER RICHTIG BEHANDELN.

ERSTE INVESTITION - RÜCKBLICKEND WAR UNBEDEUTEND. FÜR EIN UNTERNEHMEN, DAS AUS DER ASCHE DES KRIEGES HERVORGING, WAR ES JEDOCH EIN GROßER MEILENSTEIN, UNSER BÜRO UND DEN ZUKÜNFTIGEN HAUPTSITZ UM NEUE 60 QUADRATMETER ZU ERWEITERN.

2004 Expanding European Presence | ERWEITERUNG DER PRÄSENZ IN EUROPA

Through participation in leading industry trade shows and conferences in Western Europe, Provis began to understand the potential of its products. Over time, this led to many successful wholesale relationships with leading sign makers in Switzerland, Austria, Germany, Dubai and other countries, markets that expect nothing less than the best quality and multiple location program management capability.

DURCH DIE TEILNAHME AN FÜHRENDEN BRANCHENMESSEN UND KONFERENZEN IN WESTEUROPA BEGANN PROVIS DAS POTENZIAL SEINER PRODUKTE ZU VERSTEHEN. DIES FÜHRTE IM LAUFE DER ZEIT ZU ZAHLREICHEN ERFOLGREICHEN GROßHANDELSBEZIEHUNGEN MIT FÜHRENDEN WERBEHERSTELLER IN DER SCHWEIZ, ÖSTERREICH, DEUTSCHLAND UND DUBAI UND ANDERE LÄNDER, MÄRKTE DIE ERWARTEN NICHTS WENIGER ALS DIE BESTE QUALITÄT UND DIE FÄHIGKEIT ZUR VERWALTUNG MEHRERER STANDORTPROGRAMME.

2004 First Multi-location Rollout | ERSTER STANDORTÜBERGREIFENDER ROLLOUT

A major milestone was reached when Velpro, a leading wholesale supplier of food and non-food products in Southern and Southeastern Europe, chose Provis as its preferred partner for signage fabrication and installation.

EIN WICHTIGER MEILENSTEIN WURDE ERREICHT, ALS VELPRO, DER FÜHRENDE GROßHANDELSANBIETER VON LEBENSMITTELN UND NON-FOOD-PRODUKTEN IN SÜD-UND SÜDOSTEUROPA, PROVIS ALS BEVORZUGTEN PARTNER FÜR DIE HERSTELLUNG UND INSTALLATION DER BESCHILDERUNG AUSWÄHLTE.

2006 Konzum | KONZUM

Konzum, the largest grocery retailer in Southeastern Europe with more than 700 store locations, chooses Provis as its preferred signage fabrication and installation partner.

KONZUM, DER GRÖßTE LEBENSMITTELEINZELHÄNDLER IN SÜDOSTEUROPA MIT MEHR ALS 700 FILIALEN, WÄHLT PROVIS ALS BEVORZUGTEN PARTNER FÜR DIE HERSTELLUNG UND INSTALLATION VON BESCHILDERUNGEN.

2007 Expansion and New Facility | ERWEITERUNG UND NEUBAU

Provis invests into acquisition of property, plant and equipment to continue to satisfy customers' demand. In 2007, the planned renovation of newly acquired buildings was completed, including inspirational office space for our project management, design and engineering teams.

PROVIS INVESTIERT IN DEN ERWERB VON GRUNDSTÜCK, ANLAGEN UND AUSSTATTUNG, UM DIE NACHFRAGE DER KUNDEN WEITERHIN ZU BEFRIEDIGEN. 2007 WURDE DIE GEPLANTE RENOVIERUNG NEU ERWORBENER GEBÄUDE ABGESCHLOSSEN, EINSCHLIEßLICH INSPIRIERENDER BÜRORÄUME FÜR UNSERE PROJEKTMANAGEMENT-, DESIGN- UND ENGINEERING-TEAMS.

2009 New Product Development | NEUE PRODUKTENTWICKLUNG

Provis finalizes the design standards for low-profile trim-less letters, included Profile 11 (full acrylic letters with embedded LEDs) and Profile 5S, which quickly grow in popularity in Western European markets.

PROVIS FINALISIERT DESIGNSTANDARDS FÜR SCHLANKKE BUCHSTABEN OHNE UMLEIMER, DARUNTER PROFIL 11 (VOLLACRYLBUCHSTABEN MIT EINGEGOSSENEN LEDS) UND PROFIL 5S, DIE AUF DÜNNE WESTEUROPÄISCHEN MÄRKTEN RASCH AN BELIEBTHEIT GEWINNEN.

2012 Cartier | CARTIER

Provis became the preferred supplier of the illuminated logo of the Cartier brand. Through partners, Cartier logos made by Provis are installed all over the world, including Paris, Barcelona, New York, Moscow, Dubai, Rio de Janeiro just to name a few. This multiple-country program experience allowed Provis to fully integrate its enterprise resource planning (ERP) optimization software with its project management systems, ensuring customer demands were met on time every time.

PROVIS WURDE ZUM BEVORZUGTEN LIEFERANTEN DES BELEUCHTETEN LOGOS DER MARKE CARTIER. ÜBER PARTNER WERDEN CARTIER-LOGOS VON PROVIS IN DER GANZEN WELT INSTALLIERT, DARUNTER PARIS, BARCELONA, NEW YORK, MOSKAU, DUBAI UND RIO DE JANEIRO, UM NUR EINIGE ZU NENNEN. AUFGRUND DIESER ERFAHRUNG MIT PROGRAMMEN IN MEHREREN LÄNDERN KONNTE PROVIS SEINE ERP-OPTIMIERUNGSSOFTWARE (ENTERPRISE RESOURCE PLANNING) VOLLSTÄNDIG IN SEINE PROJEKTMANAGEMENTSYSTEME INTEGRIEREN UND SO SICHERSTELLEN, DASS DIE KUNDENANFORDERUNGEN JEDES MAL RECHTZEITIG EINGEHALTEN WURDEN.

2014 New Production Center | NEUES PRODUKTIONSZENTRUM

Provis is preparing the ground for the construction of a new state-of-the-art production facility, which adds 1.000 sqm to its existing production space. Each detail is planned and guided by the design and layout of the equipment to optimize production flow and production following Lean manufacturing principles.

PROVIS BEREITET DEN BAU EINER NEUEN HOCHMODERNEN PRODUKTIONSANLAGE VOR, DIE DIE BESTEHENDE PRODUKTIONSFLÄCHE UM 1.000 M² ERWEITERT. JEDES DETAIL WIRD DURCH DAS DESIGN UND LAYOUT DER AUSTRÜSTUNG GEPLANT UND GESTEUERT, UM DEN PRODUKTIONSFLUSS UND DIE PRODUKTION NACH DEN PRINZIPIEN DER LEAN MANUFACTURING ZU OPTIMIEREN.

2016 New Projects | NEUE PROJEKTE

A big growth year: Provis was awarded many new contracts for multiple-country signage rollouts, for brands including Samsung, Oracle, Adidas, Sparkasse Bank, UniCredit Bank, among a few.

EIN GROßES WACHSTUMSJAHR: PROVIS ERHIELT ZAHLREICHE NEUE AUFTRÄGE FÜR DIE BESCHILDERUNGEN IN MEHREREN LÄNDERN, FÜR MARKEN WIE SAMSUNG, ORACLE, ADIDAS, SPARKASSE BANK, UNICREDIT BANK UNTER EINIGEN.

2019 Onward and Upward | VORWÄRTS UND AUFWÄRTS

To this day, Provis leverages its strategic relationships with dedicated suppliers, research and development partners, and sign fabricator-resellers to maximize design possibilities for its end users. By the end of this year we will build new production site, and we will invest in new equipment.

BIS ZUM HEUTIGEN TAG NUTZT PROVIS SEINE STRATEGISCHEN BEZIEHUNGEN ZU ENGAGIERTEN LIEFERANTEN, FORSCHUNGS- UND ENTWICKLUNGSPARTNERN UND VERTRAGSHÄNDLERN, UM DIE GESTALTUNGSMÖGLICHKEITEN FÜR DIE ENDBENUTZER ZU MAXIMIEREN. BIS ENDE DIESES JAHRES WERDEN WIR EINE NEUE PRODUKTIONSSTÄTTE ERRICHTEN UND IN NEUE AUSTRÜSTUNG INVESTIEREN.

A series of horizontal dashed lines for taking notes, spanning the left side of the page.

Modern Gloss PRO™

Mesing PRO™



Gold PRO™



Chrom PRO™



Gray 7832 PRO™



Vintage PRO™

Gray 451 PRO™

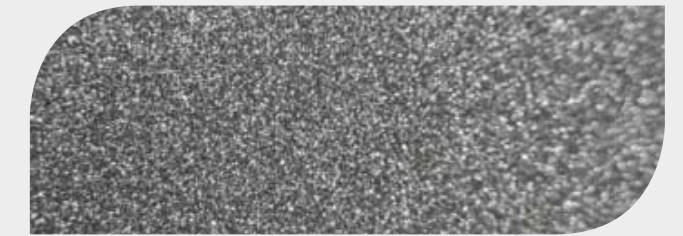

Oxyde PRO™



Manganese 2350 PRO™



Gray 452 PRO™





Provis graphic

LIGHT UP YOUR BUSINESS

Provis d.o.o.

Industrijska zona Cekrekcije bb
71300 Visoko, Bosna i Hercegovina

+387 32 737 777

info@provis.ba

www.provis.ba

